

NOMENCLATURA

- 1 - Brida
- 2 - Tapa
- 3 - Cuerpo
- 4 - Turbina
- 5 - Eje
- 6 - Aro
- 7 - Motor
- 8 - Cierre mecánico
- 9 - Tuerca ciega
- 10 - Arandela
- 11 - Chaveta
- 12 - Tornillo
- 13 - Junta tórica
- 14 - Paragotas
- 15 - Prisionero
- 16 - Tapón purga
- 17 - Tornillo
- 18 - Bancada
- 19 - Protector
- 20 - Tornillo
- 21 - Junta

NOMENCLATURE

- 1 - Flange
- 2 - Cover
- 3 - Body
- 4 - Impeller
- 5 - Shaft
- 6 - Ring
- 7 - Motor
- 8 - Mechanical seal
- 9 - Cap nut
- 10 - Washer
- 11 - Key
- 12 - Screw
- 13 - O-ring
- 14 - Splash protection
- 15 - Setscrew
- 16 - Drainage Plug
- 17 - Screw
- 18 - Base
- 19 - Protector
- 20 - Screw
- 21 - Gasket

NOTA: Las piezas de recambio recomendadas están coloreadas. / NOTE: The recommended spare parts are coloured in.

CARACTERÍSTICAS TÉCNICAS

Caudal..... Q = 1 a 50 m³/h
 Altura manométrica..... H = 5 a 50 mca
 Motores..... P = 1 a 30 hp
 (0.75 a 22 kW)
 Temperatura..... T = 100°C
 (cierre esp. 130°C)
 Material..... AISI-316L

DESCRIPCIÓN

Bomba centrífuga autocebante monobloc con cámara de cebado.

La bomba CEBAX-M es autocebante hasta 5 m sin válvula de pié. No precisa tampoco ninguna válvula de clapeta en el interior de la bomba, lo que la hace más sanitaria y apropiada para líquidos que contienen partículas sólidas.

-Cuerpo de acero inoxidable embutido en frío, espesor de 3 a 5 mm, según modelo, con cámara de cebado, pulido mate.

-Tapa ajustable desmontable, embutida en frío, espesor de 3 a 5 mm, según modelo.

-Brida de acero inoxidable embutida en frío, espesor de 3 a 5 mm, según modelo, pulida mate.

-Turbina semiabierta, obtenida mediante proceso de microfusión.

-Eje intercambiable, independiente del motor.

-Cierre mecánico simple interior Burgmann. Posible otros tipos.

-Bancada estampada de inoxidable.

-Aro seguridad atornillado.

-Protector seguridad brida CE inoxidable.

-Motor IEC IP-55 (Posible EEX).

Equipada con roscas GAS o DIN-11851 (posible SMS, FIL, CLAMP).

APLICACIONES

Aguas, cervezas, vinos, zumos, jarabes, sueros, etc.
 Ácidos, sales, disolventes, etc.

TECHNICAL SPECIFICATIONS

Flow rate..... Q = 1 to 50 m³/h
 Total head..... H = 5 to 50 mwc
 Motors..... P = 1 to 30 hp
 (0.75 a 22 kW)
 Temperature..... T = 100°C
 (special seal 130°C)
 Material..... AISI-316L

DESCRIPTION

Monobloc centrifugal pump with self-priming chamber.

The CEBAX-M is self-priming to 5 metres without a foot valve. A flap valve is not required inside the pump, which it makes it more sanitary for liquids containing solid particles.

-Cold pressed stainless steel body, 3 to 5 mm minimum thickness according to model, with priming chamber, matt finish.
 -Adjustable, removable, cold pressed

cover, 3 to 5 mm thickness according to model.

-Cold pressed stainless steel flange, 3 to 5 mm thickness according to model, matt finish.

-Semi-open impeller, obtained through a micro-fusion process.

-Replaceable shaft, independent of the motor.

-Single internal mechanical seal, Burgmann type. Other types possible.

-Pressed stainless steel base.

-Screwed safety ring.

-Stainless steel CE flange safety protector.

-Motor IEC IP-55 (possible EEX).

Fitted with GAS or DIN-11851 threads (possible SMS, FIL, CLAMP).

APPLICATIONS

Water, beer, wine, juices, syrups and whey etc.
 Acids, salts and solvents etc.

■ CURVAS CARACTERÍSTICAS / CHARACTERISTIC CURVES

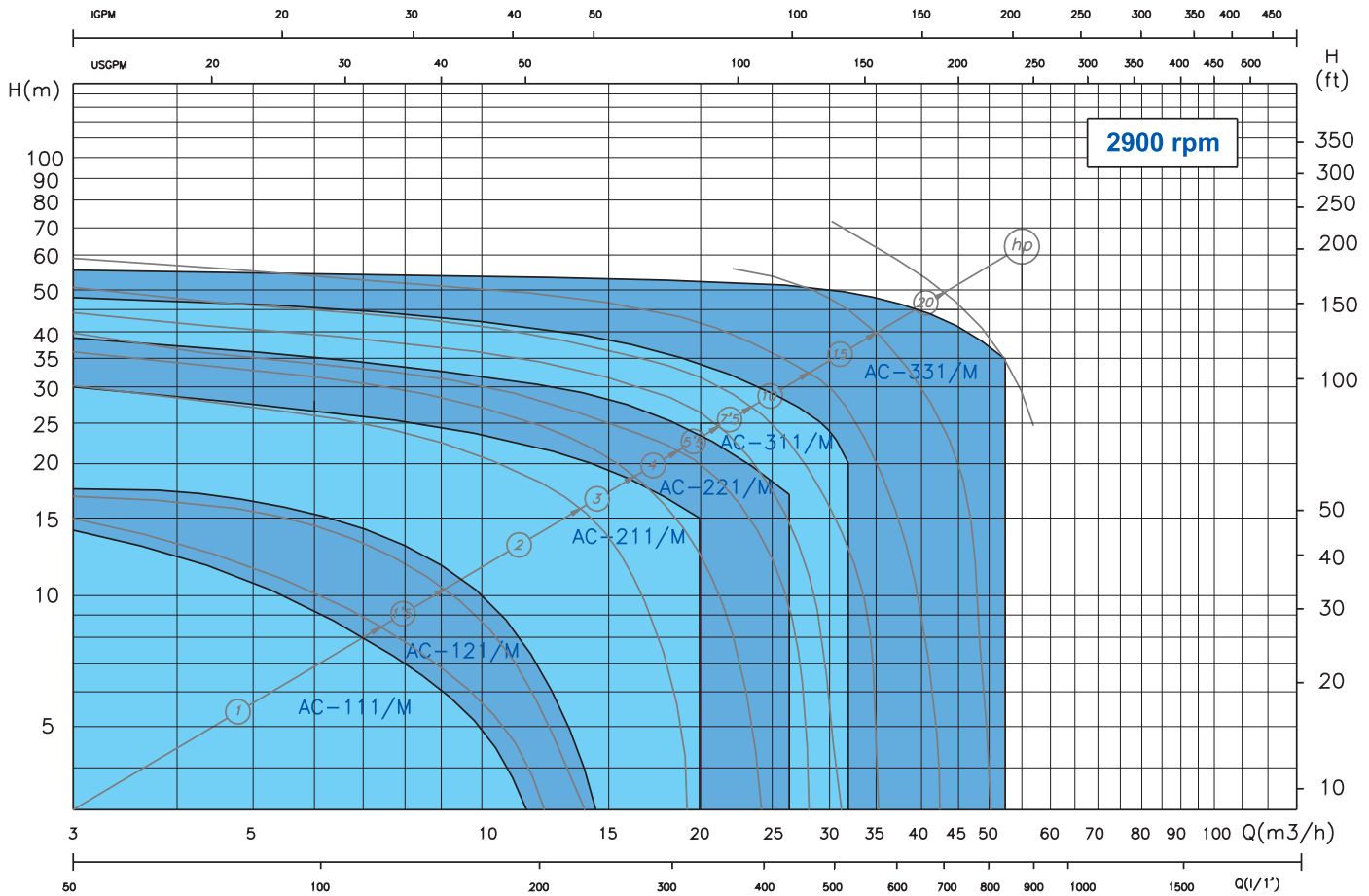

■ DIMENSIONES / DIMENSIONS

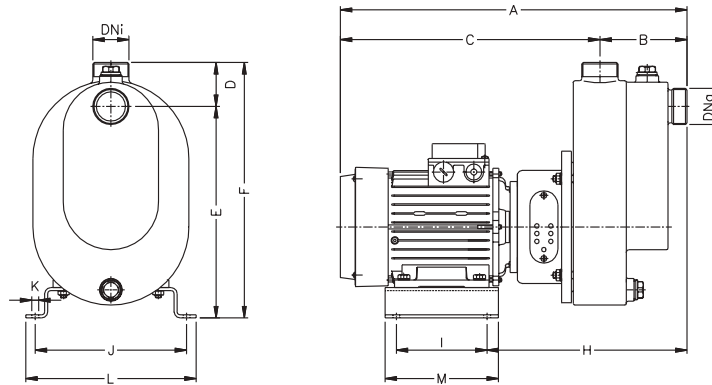

TIPO / TYPE	MOTOR / MOTOR				DIMENSIONES / DIMENSIONS (mm)													PESO / WEIGHT (kg)	
	TAMAÑO / SIZE	hp	kW	rpm	A	B	C	D	E	F	H	I	J	K	L	M	DNa		DNi
AC-111/M	80	1-1.5	0.75-1.1	3000	458	115	343	58	279	337	264	120	200	9	225	150	1 1/2" GAS	1 1/2" GAS	23-24
AC-121/M	80	1-1.5	0.75-1.1		463	120	343	63	276	339	269	120	200	9	225	150	2" GAS	2" GAS	23-24
AC-211/M	90	2-3	1.5-2.2	3000	499	135	379	63	286	349	280	135	225	11	255	170	2" GAS	2" GAS	29-31
	90	2-3	1.5-2.2		542		407	72	335	407	323	135	225	11	255	170	2" GAS	2" GAS	38-40
AC-221/M	100	4	3	3000	581	145	436	82	343	425	340	150	260	13	295	185	2 1/2" GAS	2 1/2" GAS	50
	112	5.5	4		583		438	82	365	447	340	165	285	13	320	200	2 1/2" GAS	2 1/2" GAS	55
AC-311/M	132S	7.5-10	5.5-7.5	3000	712	175	537	93	467	560	423	200	335	13	370	250	2 1/2" GAS	2 1/2" GAS	102-112
	160M	15-20	11-15		872		693	93	495	590	489	250	400	13	434	340	2 1/2" GAS	2 1/2" GAS	158-161
AC-331/M	160L	25	18.5	3000	913	179	734	95	495	50	489	250	00	13	434	340	NW-80	NW-80	173
	180M	30	22		949		770	95	515	610	488	290	445	15	490	380	NW-80	NW-80	202



Bominox, S.A.
Ctra. Banyoles, km.14
17844 Cornellà de Terri (Girona) Spain
Apart. 123 Banyoles

Tel. 34 972 59 50 20
Fax 34 972 59 51 20
E-mail: info@bominox.com
www.bominox.com