

A 316



A 316-130S



A 316-550T

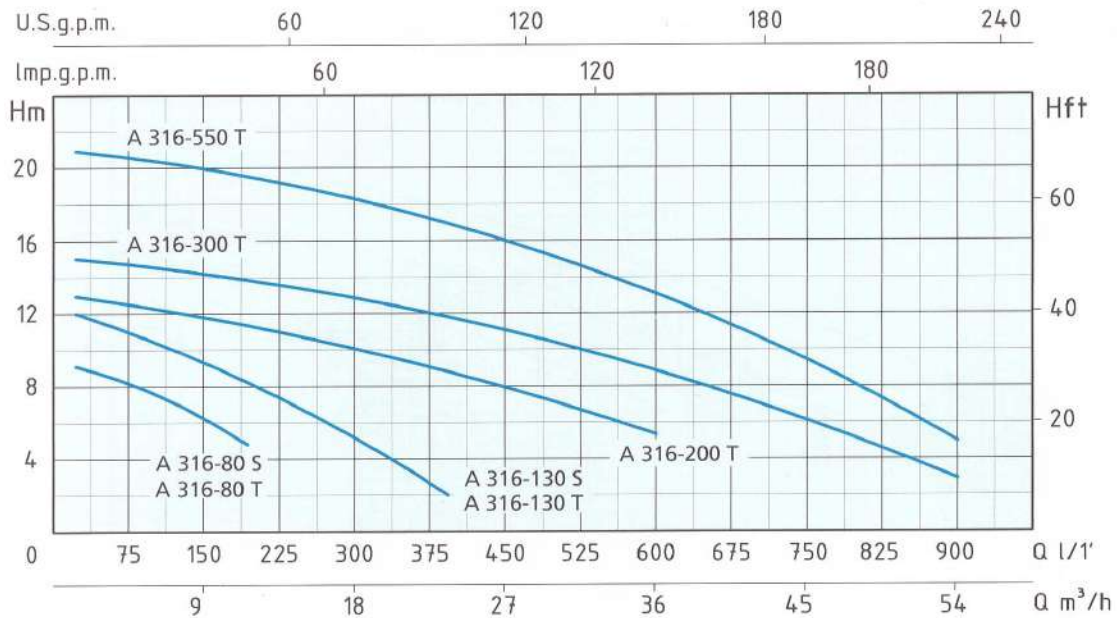

TIPO TYPE		POTENZA NOMINALE NOMINAL POWER		AMPERE		Q = PORTATA - CAPACITY											
Monofase Single-phase	Trifase Three-phase	P2		Monofase Single-phase	Trifase Three-phase	m³/h	1,5	3	6	8	9	12	24	36	48	54	
		HP	kW														1 x 230V
230V-50Hz	230/400V-50Hz					Prevalenza manometrica totale in m.C.A. - Total head in meters w.c.											
A316-80 S	A 316-80 T	0,8	0,6	3	1	H (m)	9,2	8,5	7,3	6,3	6,1	5					
A316-130 S	A 316-130 T	1,3	1	4,8	1,9		12	11,7	10,5	9,7	9,2	8	2				
	A 316-200 T	2	1,5		3,5		12,5	11,9	11,4	11,1	10,9	10,5	9	5,4			
	A 316-300 T	3	2,2		5,5		15,7	15,4	15	14,6	14,4	14,2	13	9	5	3	
	A 316-550 T	5,5	4		12,2		21	20,5	20	19,8	19,6	19	16,8	13,8	8	5	

APPLICAZIONI

Elettropompe per drenaggio con girante in acciaio inox che assicura ampi passaggi liberi ed elevate prestazioni. Adatta per la movimentazione di liquidi fognari e biologici carichi, fanghi attivi e per liquidi non depurati da griglie, per scarichi di origine civile ed industriali e per liquidi particolarmente aggressivi, salini e corrosivi.

LIMITI D'IMPIEGO

- Temperatura liquido fino a 35°C (per un uso domestico secondo EN 60335-2-41)
Temperatura max. liquido: 40°C (per altri impieghi)
- Massima profondità d'immersione 30 mt. (con cavo di adatta lunghezza)
- Livello min. d'aspirazione 150 mm
- Servizio continuo

MOTORE

- Isolamento Classe F
- Protezione IP 68
- Protettore termico
- Funzionamento a secco

MATERIALI

- Corpo motore Acciaio Inox AISI 316
- Corpo pompa Acciaio Inox AISI 316
- Coperchio superiore Acciaio Inox AISI 316
- Girante Acciaio Inox AISI 316
- Cilindro motore Acciaio Inox AISI 316
- Albero motore Acciaio Inox AISI 316
- Doppia tenuta meccanica in camera d'olio Ceramica/Grafite/Viton
Silicio/Silicio/Viton

APPLICATION

Submersible drainage pumps with inox impeller, which allows free passage of suspended parts and high performance. Suitable in civil and industrial water systems, for cesspool drainage with dirty and muddy liquids and for waters not cleaned by grid and for particularly aggressive liquids, salt and corrosive.

OPERATING CONDITIONS

- Liquid temperature up to 35°C (for home use according to EN 60335-2-41)
Temperature max. liquid: 40°C (for other uses)
- Maximum immersion depth 30 mt. (with a cable of the appropriate length)
- Min. suction level 150 mm
- Continuous duty

MOTOR

- Insulation Class F
- Protection IP 68
- Thermic protection
- Dry type

MATERIALS

- Motor body Stainless Steel AISI 316
- Pump body Stainless Steel AISI 316
- Upper cover Stainless Steel AISI 316
- Impeller Stainless Steel AISI 316
- Casing Stainless Steel AISI 316
- Shaft with rotor Stainless Steel AISI 316
- Double mechanical seal in oil chamber Ceramic/Graphite/Viton
Silicon/Silicon/Viton

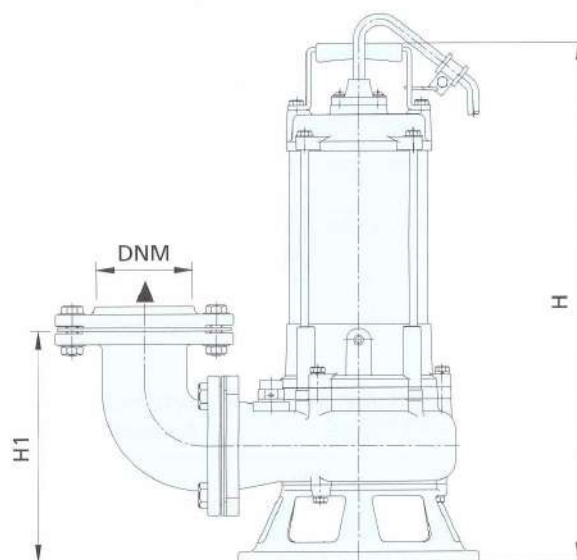
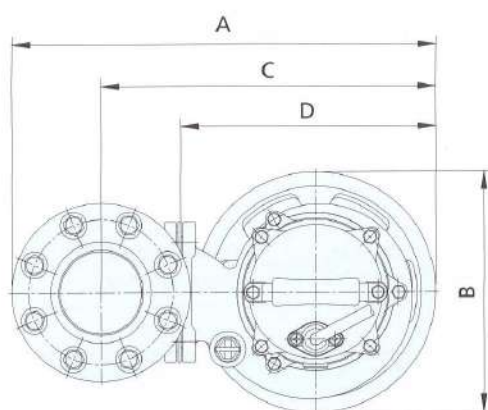

TIPO TYPE		DIMENSIONI mm - DIMENSIONS mm							DIMENSIONI DIMENSIONS mm			PESO WEIGHT	
Monofase Single-phase	Trifase Three-phase	A	B	C	D	H	H1	DNM	CAVO CABLE	P	L	H	Kg
A316-80 S	A 316-80 T	237	154	199	-	427	99	2"	10 mt H07RNF	200	260	480	18
A316-130 S	A 316-130 T	237	154	199	-	427	99	2"	10 mt H07RNF	200	260	480	20
	A 316-200 T	441	250	348	325	538	241	3"	10 mt H07RNF	280	280	630	36
	A 316-300 T	441	250	348	325	563	241	3"	10 mt H07RNF	280	280	630	37
	A 316-550 T	453	216	360	337	572	192	3"	10 mt H07RNF	440	400	820	54